



CROSSFIRE

N2

NANO POWER

Octa Band Digital Radios
20dBm per Band
5G NR Compliant
Integrated Antennas
Integrated Bluetooth

OVERVIEW

CrossFire N2 is a digital transmission platform supporting CPRI protocol over the fiber optic cable for cellular, GigE IP and public safety technologies. The digital radio supports (8) 3GPP bands with a combined EIRP utilization value of almost 1 Watt, with integrated antennas for cellular and Bluetooth beaconing, and optional integrated Wi-Fi. The N2 platform is part of the CrossFire 2.0 generation, supporting 5G technology from 360MHz to 3.8GHz, and future RAN virtualization technology.

KEY FEATURES

- 5G NR Compliance from 360 to 3800MHz Range
- (8) 3GPP Band per Remote
- 20dBm Output Power per Band
- Up to 100MHz IBW per Band
- Octa Band SISO/Quad Band 2x2 MIMO/ Dual Band 4x4 MIMO
- IP Transport and Bluetooth
- Integrated Antenna or External Antenna
- Optical cascading of EU-O's & RU's

SYSTEM ELEMENTS



A2
Access Unit



EU-O
Optical
Expansion Unit



N2RU
Nano Power
Remote Unit

BLOCK DIAGRAM

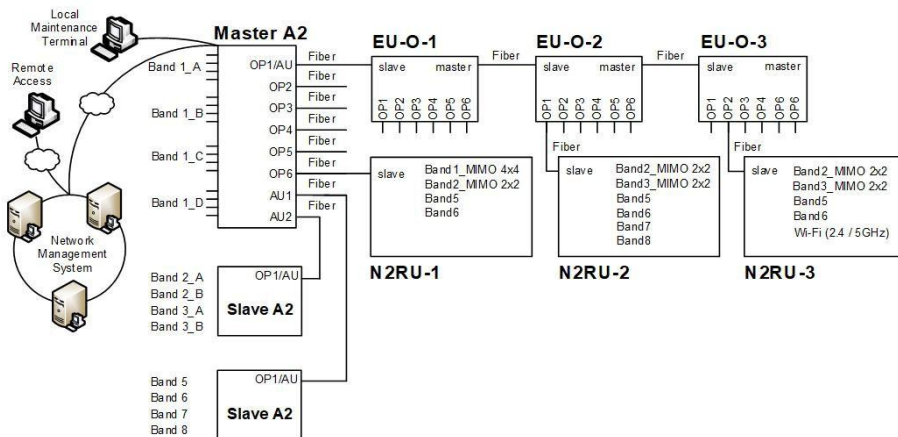

TECHNICAL SPECIFICATIONS	
System	
Maximum RF Bands per Access Unit	4
Maximum RF Bands per Remote Unit	8 (6 with integrated Wi-Fi)
Maximum RF Bands per System	12
Maximum Access Units per System	3 (1 x Master / 2 x Slaves)
Maximum EUs per Master AU	8
Maximum RUs per EU	12
Maximum RUs cascaded	0
Frequency Range (Non-Contiguous)	360MHz – 3800MHz
Bandwidth per Channel (Downlink & Uplink)	≤100MHz (Contiguous)
Digital Bandwidth per Channel (Downlink & Uplink)	20 / 30 / 40 / 50 / 60 / 80 / 100 MHz
Bandwidth per System (Downlink & Uplink)	≤360MHz + 1GB/s IP (100MB/s if >360MHz RF Bandwidth) ≤400MHz Maximum
MIMO	2 x 2: 1 x RU (x4) 4 x 4: 1 x RU (x2) 8 x 8: 1 x RU (x1)
IP Transmission Rate per RU	1GB/s (100MB/s if >360MHz RF Bandwidth)
Maximum IP Connections per EU	6
Maximum IP Connections per RU	1
System Delay Adjustment	Up to 80.00μs

FORWARD PATH (DOWNLINK)					
	Number of Carriers	1	2	4	8
Output Power per Carrier	Frequency higher than 1GHz	20	17	14	11
	Frequency lower than 1GHz	17	14	11	8
Output Power Accuracy	±2dB				
Maximum Gain	20 ± 3dB for frequency higher than 1GHz 17 ± 3dB for frequency lower than 1GHz				
Maximum Input Power	+15dBm (with AGC operating) / 0dBm (without AGC operating)				
Error Vector Magnitude	<3.5% @ 256 QAM				
Ripple	4dB Typical				
Manual Attenuation Control	30dB @ 1dB/step (AU:20dB, RU:15dB)				
System Delay (AU+EU+RU)	8μS				

REVERSE PATH (UPLINK)	
Maximum Output Power per Band	-20dBm
Output Power Accuracy	± 2dB
Maximum Gain	20 ± 3dB
Maximum Input Power	-25dBm
Ripple	4dB Typical
Manual Gain Control	30dB @ 1dB/step (AU:20dB, RU:15dB)
System Delay (AU+EU+RU)	8μS
Noise Figure	10dB Typical @ Maximum Gain

SUPPORTED BANDS				
Band	3GPP Band	Downlink	Uplink	Max Bandwidth
600MHz	71	617-652	663-698	35
700MHz A	28	758-788	703-733	30
700MHz B	28	773-803	718-748	30
700MHz Lower	12	729-746	699-716	17
700MHz Upper	13	746-756	777-787	10
700MHz Safety	14	758-768	788-798	10
800MHz	20	791-821	832-862	30
850MHz	5	869-894	824-849	25
850E MHz	26	859-894	814-849	35
900MHz	8	925-960	880-915	35
1800MHz	3	1805-1880	1710-1785	75
1900MHz	25	1930-1995	1850-1915	65
2100MHz	66	2110-2180	1710-1780	70
2100MHz	1	2110-2170	1920-1980	60
2300MHz	30	2350-2360	2305-2315	10
2300MHz TDD	40	2300-2400	2300-2400	100
2500MHz TDD	41	2496-2690	2496-2690	100
2600MHz TDD	38	2570-2620	2570-2620	50
2600MHz	7	2620-2690	2500-2570	70
3500MHz TDD	42	3400-3600	3400-3600	100
3700MHz TDD	43	3600-3800	3600-3800	100
3600MHz CBRS	48	3550-3700	3550-3700	100

INTERFACES	
Antenna Interface (All bands)	QMA Female
Access Unit RF Interface	QMA Female
Transmission Connector Type	SFP+, Standard LC
Transmission Rate	10.1376GB/s
Optical Fibre Length	1.4km / 10km / 30km 0.87mi / 6.21mi / 18.64mi
Physical Alarms	DB9, Female (4x in, 4x out)
Maintenance Interface	Ethernet RJ45 / Wi-Fi / USB

ELECTRICAL	
Electromagnetic Compatibility/Interference (EMC/EMI)	3GPP TS36.113 3GPP TS25.113
Maximum Power Consumption (AU/EU-E/RU)	80W/ 50W/ 98W
AC Power	AU: 100-240V AC, 50/60Hz (AU & EU-O)
DC Power	AU: 48VDC ± 20% (AU, EU-O and RU)

ENVIRONMENTAL	
Mean Time Between Failure (MTBF)	>80,000 hours
Operating Temperature (AU/EU)	-10°C ~ 50°C/ 14°F ~ 122°F
Operating Temperature (RU)	-10°C ~ 40°C/ 14°F ~ 104°F
Storage Temperature	-40°C ~ 70°C / -40°F ~ 158°F
Humidity	5% ~ 85% (Non-Condensing)
Cooling	Passive (AU & EU-O) / Active (RU Only)
Installation	AU/EU: Wall or 19" Rack RU: Ceiling or Wall
Ingress Protection Rating	IP30 (Indoor)

MECHANICAL	
AU: Width x Height x Depth (Weight)	440mm x 44mm x 329mm (8.0kg) 17.32in x 1.73in x 12.95in (17.64lbs)
EU-O: Width x Height x Depth (Weight)	440mm x 44mm x 220mm (5.0kg) 17.32in x 1.73in x 8.66in (11.02lbs)
RU(N2RU-I-Cove): Width x Height x Depth (Weight)	220mm x 55mm x 220mm (7.0kg) 8.66in x 2.16in x 8.66in (15.43lbs)
RU(N2RU-X-Cove): Width x Height x Depth (Weight)	220mm x 65mm x 220mm (3.1kg) 8.66in x 2.56in x 8.66in (6.83lbs)

ELEMENT MANAGEMENT	
OMT (Operations and Maintenance Terminal)	Yes. Access via AU, EU or RU (Web Based)
LMS (Local Management System)	Yes (Ordered separately)
NMS (Network Management System)	Yes (Ordered separately)

ORDERING INFORMATION

Part Code	Part Description
Access Unit Chassis (2nd Generation)	
A2-4-AC	Access Unit Chassis, 4 Bands, 360 - 3800MHz supported, 100-240v AC Powered
A2-4-DC	Access Unit Chassis, 4 Bands, 360 - 3800MHz supported, \pm 48v DC Powered
Access Unit Modules	
AU-AC-M600	Access Unit Module, 4 Way Active Combiner 600MHz (UL 663-698 / DL 617-652)
AU-AC-M700	Access Unit Module, 4 Way Active Combiner 700MHz (UL 703-748/ DL 758-803)
AU-AC-M700L	Access Unit Module, 4 Way Active Combiner 700MHz Lower (UL 698-716/ DL 728-746)
AU-AC-M700U	Access Unit Module, 4 Way Active Combiner 700MHz Upper (UL 776-787/ DL 746-757)
AU-AC-M700S	Access Unit Module, 4 Way Active Combiner 700MHz Safety (UL 788-798/ DL 758-768)
AU-AC-M800	Access Unit Module, 4 Way Active Combiner 800MHz (UL 832-862/ DL 791-821)
AU-AC-M850	Access Unit Module, 4 Way Active Combiner 850MHz (UL 824-849/ DL 869-894)
AU-AC-M850E	Access Unit Module, 4 Way Active Combiner 850MHz Extended (UL 814-849/ DL 859-894)
AU-AC-M900	Access Unit Module, 4 Way Active Combiner 900MHz (UL 880-915/ DL 925-960)
AU-AC-M1800	Access Unit Module, 4 Way Active Combiner 1800MHz (UL 1710-1785/ DL 1805-1880)
AU-AC-M1900	Access Unit Module, 4 Way Active Combiner 1900MHz (UL 1850-1915/ DL 1930-1995)
AU-AC-M2100A	Access Unit Module, 4 Way Active Combiner 2100MHz AWS (UL 1710-1780/ DL 2110-2180)
AU-AC-M2100	Access Unit Module, 4 Way Active Combiner 2100MHz (UL 1920-1980/ DL 2110-2170)
AU-AC-M2300	Access Unit Module, 4 Way Active Combiner 2300MHz (UL 2305-2315/ DL 2350-2360)
AU-AC-M2300T	Access Unit Module, 4 Way Active Combiner 2300MHz TDD (2300-2400)
AU-AC-M2500T	Access Unit Module, 4 Way Active Combiner 2500MHz TDD (2496-2690)
AU-AC-M2600T	Access Unit Module, 4 Way Active Combiner 2600MHz TDD (2570-2620)
AU-AC-M2600	Access Unit Module, 4 Way Active Combiner 2600MHz (2500-2570/ 2620-2690)
AU-AC-M3500T	Access Unit Module, 4 Way Active Combiner 3500MHz TDD (3400-3600)
AU-AC-M3600T	Access Unit Module, 4 Way Active Combiner 3600MHz TDD CBRS(3550-3700)
AU-AC-M3700T	Access Unit Module, 4 Way Active Combiner 3700MHz TDD (3600-3800)
AU/RU-NC	Blanking Card to suit AU or Indoor Low Power RU
Expansion Units	
EU-O-6-AC	Expansion Unit Supports up to 6 x Optical Outputs. 100-240v AC Powered
EU-O-6-DC	Expansion Unit Supports up to 6 x Optical Outputs. \pm 48v DC Powered
Remote Unit Chassis (2nd Generation)	
N2RU-I-8-DC	Indoor Nano Remote Chassis, 400MHz, 8 Bands. Includes 1 pair simplex LC SFP+. \pm 48v DC Powered
N2RU-I-Cover	Indoor Nano Remote Cover, supports 8 bands with integrated antennas
N2RU-X-Cover	Indoor Nano Remote Cover, supports 8 bands with external duplexed ports
Other Items	
FAN-1U-AC	AC Fan Unit to support AU & LPRU Chassis, 1U Rack Unit Height, 100-240v AC Powered
FAN-1U-DC	DC Fan Unit to support AU & LPRU Chassis, 1U Rack Unit Height, \pm 48v DC Powered
SFP+1.4-SS	1.4km Optical SFP+ Module, Simplex, Single-Mode (Sold as a pair)
SFP+10-DS	10.0km Optical SFP+ Module, Duplex, Single-Mode (Sold as a pair)

Remote Unit Modules	
N2RU-WIFI	Indoor Nano Radio Module, 23dBm, 2.4G/5GHz WIFI, 2x2 MIMO
N2RU-M600	Indoor Nano Radio Module, 17dBm, 600MHz (UL 663-698 / DL 617-652)
N2RU-M700A	Indoor Nano Radio Module, 17dBm, 700MHz Option A (UL 703-733 / DL 758-788)
N2RU-M700B	Indoor Nano Radio Module, 17dBm, 700MHz Option B (UL 718-748 / DL 773-803)
N2RU-M700L	Indoor Nano Radio Module, 17dBm, 700MHz Lower (UL 699-716 / DL 729-746)
N2RU-M700U	Indoor Nano Radio Module, 17dBm, 700MHz Upper (UL 777-787 / DL 746-756)
N2RU-M700S	Indoor Nano Radio Module, 17dBm, 700MHz Safety (UL 788-798 / DL 758-768)
N2RU-M800	Indoor Nano Radio Module, 17dBm, 800MHz (UL 832-862 / DL 791-821)
N2RU-M850	Indoor Nano Radio Module, 17dBm, 850MHz (UL 824-849 / DL 869-894)
N2RU-M850E	Indoor Nano Radio Module, 17dBm, 850E MHz (UL 814-849 / DL 859-894)
N2RU-M900	Indoor Nano Radio Module, 17dBm, 900MHz (UL 880-915 / DL 925-960)
N2RU-M1800	Indoor Nano Radio Module, 20dBm, 1800MHz (UL 1710-1785 / DL 1805-1880)
N2RU-M1900	Indoor Nano Radio Module, 20dBm, 1900MHz (UL 1850-1915 / DL 1930-1995)
N2RU-M2100	Indoor Nano Radio Module, 20dBm, 2100MHz (UL 1920-1980 / DL 2110-2170)
N2RU-M2100A	Indoor Nano Radio Module, 20dBm, 2100MHz (UL 1710-1780 / DL 2110-2180)
N2RU-M2300	Indoor Nano Radio Module, 20dBm, 2300MHz (UL 2305-2315 / DL 2350-2360)
N2RU-M2300T	Indoor Nano Radio Module, 20dBm, 2300MHz TDD (2300-2400)
N2RU-M2500T	Indoor Nano Radio Module, 20dBm, 2500MHz TDD (2496-2690)
N2RU-M2600T	Indoor Nano Radio Module, 20dBm, 2600MHz TDD (2570-2620)
N2RU-M2600	Indoor Nano Radio Module, 20dBm, (UL 2500-2570 / DL 2620-2690)
N2RU-M3500T	Indoor Nano Radio Module, 20dBm, 3500MHz TDD (3400-3600)
N2RU-M3600T	Indoor Nano Radio Module, 20dBm, 3600MHz TDD CBRS (3550-3700)

Contact Us

www.btiwireless.com

sales@btiwireless.com